

# Explorer 100 Series

## User Guide

# Contents

<a href="#">What's in the box</a>	<a href="#">3</a>
<a href="#">Headset overview</a>	<a href="#">4</a>
<a href="#">Pair</a>	<a href="#">5</a>
<a href="#">Get paired</a>	<a href="#">5</a>
<a href="#">Pair mode</a>	<a href="#">5</a>
<a href="#">Basics</a>	<a href="#">6</a>
<a href="#">Answer or end a call</a>	<a href="#">6</a>
<a href="#">Adjust the volume</a>	<a href="#">6</a>
<a href="#">Mute</a>	<a href="#">6</a>
<a href="#">Redial</a>	<a href="#">6</a>
<a href="#">Voice control</a>	<a href="#">6</a>
<a href="#">Select language</a>	<a href="#">6</a>
<a href="#">Pair mode</a>	<a href="#">6</a>
<a href="#">Charge and fit</a>	<a href="#">7</a>
<a href="#">Charge</a>	<a href="#">7</a>
<a href="#">Adjust the fit</a>	<a href="#">7</a>
<a href="#">Headset Features</a>	<a href="#">8</a>
<a href="#">Music and more</a>	<a href="#">8</a>
<a href="#">Decipher the lights</a>	<a href="#">8</a>
<a href="#">Voice prompts</a>	<a href="#">8</a>
<a href="#">DeepSleep mode</a>	<a href="#">8</a>
<a href="#">Install the app</a>	<a href="#">8</a>
<a href="#">Specifications</a>	<a href="#">9</a>
<a href="#">Support</a>	<a href="#">10</a>

# What's in the box



Headset



Car vent clip\*



Vehicle power charger\*

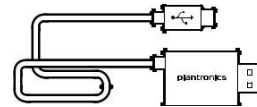

2-in-1 combo cable\*

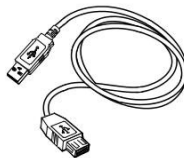

Micro USB cable\*









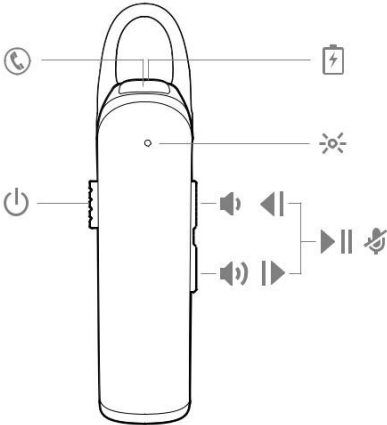



Optional earloop

**NOTE** \*Accessories may vary by product.

# Headset overview



-  Call button
-  Charge port
-  Headset LED (indicator light)
-  Power button
-  Volume up
-  Volume down
-  Track back
-  Track forward
-  Play/pause
-  Mute
-

# Pair

**Get paired**      The first time you power on your headset, the pairing process begins.

- 1 Slide the power switch on. You hear "pairing" and the indicator  light flashes red and blue.

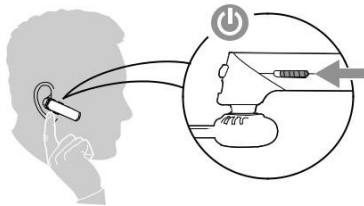

- 2 Activate Bluetooth<sup>®</sup> on your phone and set it to search for new devices.
  - **iPhone** Settings > Bluetooth > On\*
  - **Android** Settings > Bluetooth: On > Scan for devices\* **NOTE** \*Menus may vary by device.
- 3 Select "PLT E100 Series."

If necessary, enter four zeros (0000) for the passcode or accept the connection.

Once successfully paired, you hear "pairing successful" and the indicator  light stops flashing.

**Pair mode**      While wearing your headset, power it on. Press and hold the Call  button until you hear "pairing." You can pair up to 2 devices to your headset.

# Basics

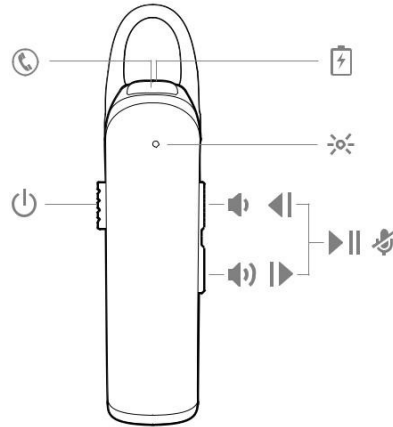

Answer or end a call	Tap the Call ☎ button.
Adjust the volume	Tap the Volume up 🔊 or Volume down 🔊 button.
Mute	During a conversation, press both the Volume up 🔊 and Volume down 🔊 buttons for 2 seconds until you hear “mute on” or “mute off.”
Redial	Double-tap the Call ☎ button to call the last number you dialed.
Voice control	<b>Siri, Google Now™, Cortana</b> Press the Call ☎ button for 2 seconds and wait for the phone prompt to activate voice dialing, search, and other smartphone voice controls.
Select language	Press and hold the Volume up 🔊 and down 🔊 buttons together until you hear “welcome.” Follow the voice-guided prompts to select the headset language.* <b>NOTE</b> *Language selection not available in Europe, Russia and Africa.
Pair mode	While wearing your headset, power it on. Press and hold the Call ☎ button until you hear “pairing.” You can pair up to 2 devices to your headset.

# Charge and fit

**Charge** It takes 2 hours to fully charge the headset; the indicator  light turns off once charging is complete.

**Adjust the fit** The universal-fit eartip has a thin loop that bends to gently tuck into the contours of either ear. To adjust the fit, you can rotate the eartip on the headset or add the optional clip-on earloop.

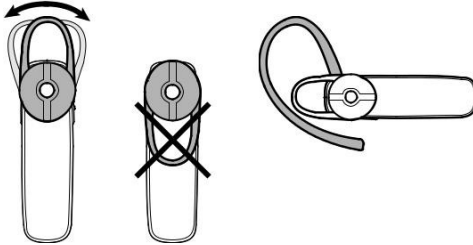

# Headset Features

**Music and more** Listen to your music, podcasts, navigation and other streaming audio on your headset.

**Play or pause audio**

Press both Volume buttons at the same time.

**Skip to next track**

Press the Volume up  button for 2 seconds.

**Play previous track**

Press the Volume down  button for 2 seconds to restart current track. Press the button twice (each button press 2 seconds) to go to previous track.

**Decipher the lights**

Your headset has an indicator light  that flashes in response to a change in status or after a button press.

Some examples of what you will see are:

- Solid red until charging complete and then solid blue
- Flashing red and blue during pairing
- Double red flash when battery low
- Double blue flash at incoming call

**Voice prompts**

Your headset tells you about status changes. For example: “Power on”

“Pairing successful”

“Phone 1 connected”

“Talk time (x) hours”

“Mute on” “Answering

call” “Recharge

headset”

**DeepSleep mode**

If you leave your headset powered on but out of range of your paired phone for more than 120 minutes, your headset will conserve its battery power by entering into a DeepSleep<sup>®</sup> mode.

Once back in range with your phone, press any button to exit DeepSleep mode. If your phone is also ringing, tap the Call  button again to answer your call.

**Install the app**

Get the most from your headset by installing our free mobile app, Plantronics Hub for iOS/ Android. Explore all of your headset’s features, view instructions, and contact Plantronics support easily from your smartphone.

[plantronics.com/apps](https://plantronics.com/apps)





# Specifications

<b>Talk Time</b>	Up to 7 hours
<b>Standby Time</b>	Up to 11 days
<b>Operating Distance (Range)</b>	Up to 33 feet (10 meters) from phone or table, Class II
<b>Headset Weight</b>	7.8 grams
<b>Charge Connector</b>	Micro USB charging
<b>Battery Type</b>	Rechargeable non-replaceable lithium ion polymer
<b>Charge Time (Maximum)</b>	2 hours for full
<b>DeepSleep mode</b>	Provides up to 180 days
<b>Power Requirements</b>	5V DC – 150 mA
<b>Bluetooth Version</b>	Bluetooth v4.1
<b>Bluetooth Profiles</b>	Hands-Free Profile v1.6 (HFP), Headset Profile v1.2 (HSP), Simple Secure Pairing (SSP)
<b>Moisture Protection</b>	No
<b>Operating Temperature</b>	32°F - 102°F (0 - 40°C)
<b>Storage Temperature</b>	32°F - 102°F (0 - 40°C)
<b>Charging Temperature</b>	32°F - 104°F (0 - 40°C)